

SYSTEMY NAPINAJĄCE

 Śruby

 Nakrętki

 Osłony

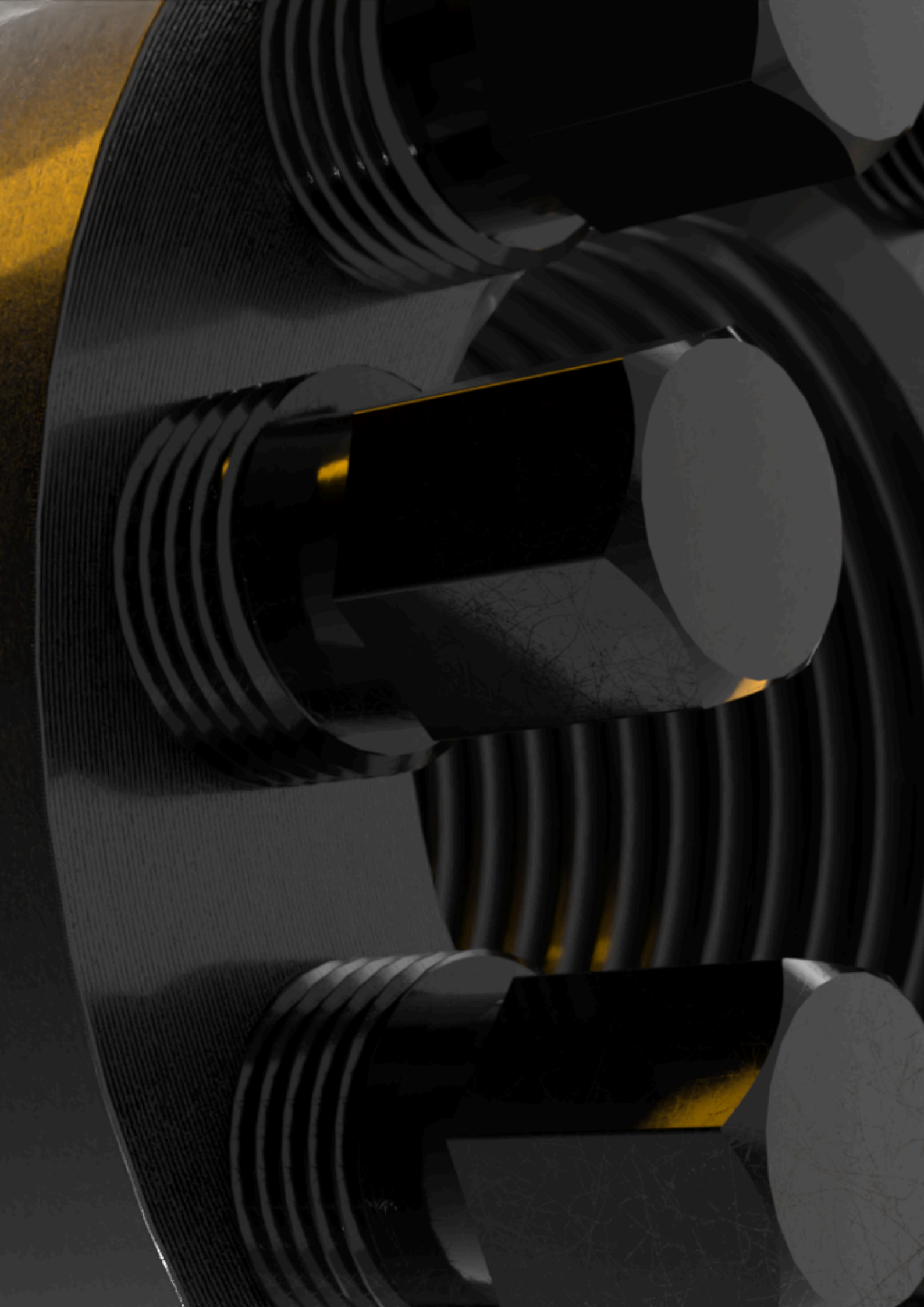



**DOKRĘCANIE
DUŻYCH
GWINTÓW
NIGDY NIE
BYŁO
PROSTSZE.**



**BRAK WZGLĘDNEGO OBROTU ŚRUBY
I NAKRĘTKI**



**STABILNOŚĆ NAPRĘŻENIA ŚRUBY
GŁÓWNEJ**



**RÓWNOMIERNE OBCIĄŻENIE
WSZYSTKICH NITEK GWINTU**



**ZNACZNE ZMNIEJSZENIE
PRACOCHOŃNOŚCI MONTAŻU**



PEWNOŚĆ DEMONTAŻU



**WYSOKA PRECYZJA WYWOŁANIA
OKREŚLONYCH NAPRĘŻEŃ**



**DOPUSZCZALNA ODCHYŁKA
PROSTOPADŁOŚCI OSI ŚRUBY**

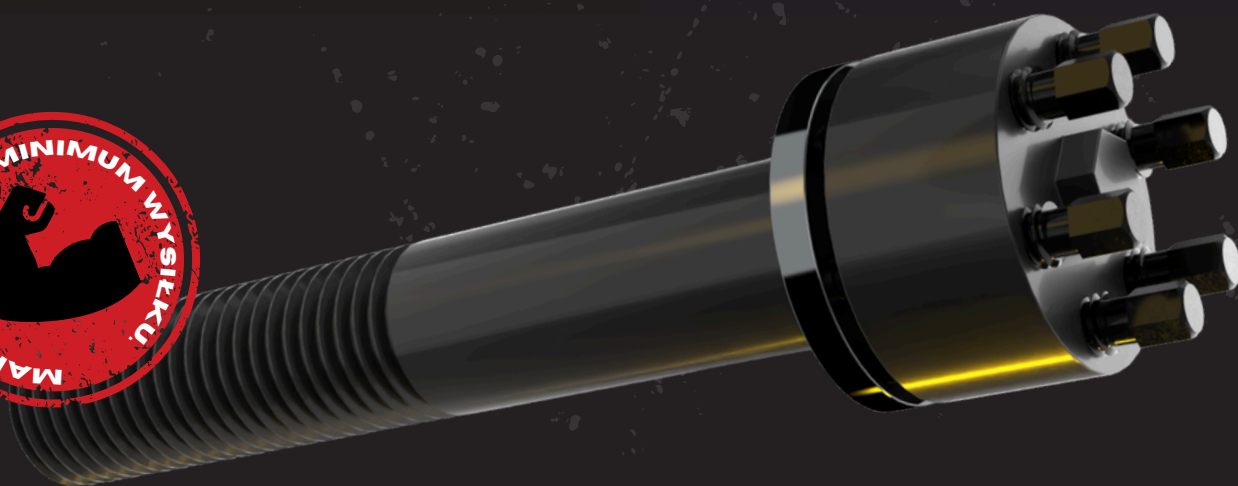

do mocowania elementów w połączeniach rurowych

- naprężenia w rdzeniu śruby ~200 N/mm²
- temp. pracy -10 ÷ +250°C
- możliwe inne wykonania i zarysy gwintów

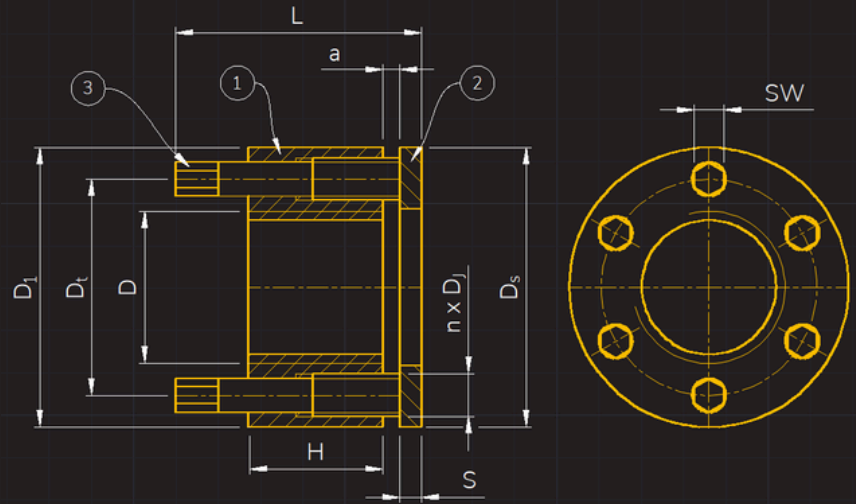

- 1 - korpus nakrętki
 2 - pierścień oporowy
 3 - śruba robocza

	D	D1	H	DT	DJ	n	SW	a	DS	S	L	waga	Mnom	Fnom
	[mm]					[szt]	[mm]					[kg]	[Nm]	[kN]
PC-M36x4-N	M36	93	38	77	M10x1.25	6	7	5	93	5	56	2.00	34	165
PC-M39x4-N	M39	95	38	80	M10x1.25	6	7	5	95	5	56	2.00	41	200
PC-M42x4.5-N	M42	99	38	83	M10x1.25	8	7	5	99	5	56	2.15	35	225
PC-M45x4.5-N	M45	102	38	86	M10x1.25	8	7	5	102	5	56	2.25	41	265
PC-M48x5-N	M48	105	45	89	M12x1.25	6	9	6	105	6	67	2.85	74	300
PC-M52x5-N	M52	111	45	93	M12x1.25	8	9	6	111	6	67	3.15	65	350
PC-M56x5.5-N	M56	115	45	97	M12x1.25	8	9	6	115	6	67	3.30	75	405
PC-M60x5.5-N	M60	119	45	101	M12x1.25	10	9	6	119	6	67	3.45	71	480
PC-M64x6-N	M64	129	64	105	M16x1.5	6	12	8	129	8	94	5.80	175	530
PC-M72x6-N	M72	137	64	113	M16x1.5	8	12	8	137	8	94	6.30	170	690
PC-M80x6-N	M80	145	64	121	M16x1.5	10	12	8	145	8	94	6.80	175	890
PC-M90x6-N	M90	156	64	131	M16x1.5	12	12	8	156	8	94	7.55	185	1130
PC-M100x6-N	M100	178	81	148	M20x1.5	10	16	7	178	10	112	12.75	345	1410
PC-M110x6-N	M110	188	81	158	M20x1.5	12	16	7	188	10	112	13.00	355	1750
PC-M120x6-N	M120	198	81	168	M20x1.5	14	16	7	198	10	112	14.50	365	2090
PC-M125x6-N	M125	203	81	173	M20x1.5	14	16	7	203	10	112	15.00	395	2270
PC-M130x6-N	M130	208	102	178	M20x1.5	16	16	12	208	10	138	19.00	370	2420
PC-M140x6-N	M140	218	102	188	M20x1.5	18	16	12	218	10	138	20.25	390	2880
PC-M150x6-N	M150	228	102	198	M20x1.5	20	16	12	228	10	138	21.25	400	3280
PC-M160x6-N	M160	238	102	208	M20x1.5	24	16	12	238	10	138	22.50	385	3790

D - gwint | D1 - śr. zewnętrzna | H - wysokość nakrętki | DT - śr. podziałowa | DJ - gwint śruby roboczej | n - ilość śrub roboczych | SW - szerokość 6-kąta | a - szczelina | DS - śr. pierścienia oporowego | S - grubość pierścienia oporowego | L - wysokość całkowita | Mnom - moment dokręcania śrub roboczych | Fnom - siła napinająca połączenie

zamiennik nakrętek sześciokątnych - klasa własności 10

- naprężenia w rdzeniu śruby ~500÷900 N/mm²
- temp. pracy -10 ÷ +250°C
- możliwe inne wykonania i zarysy gwintów

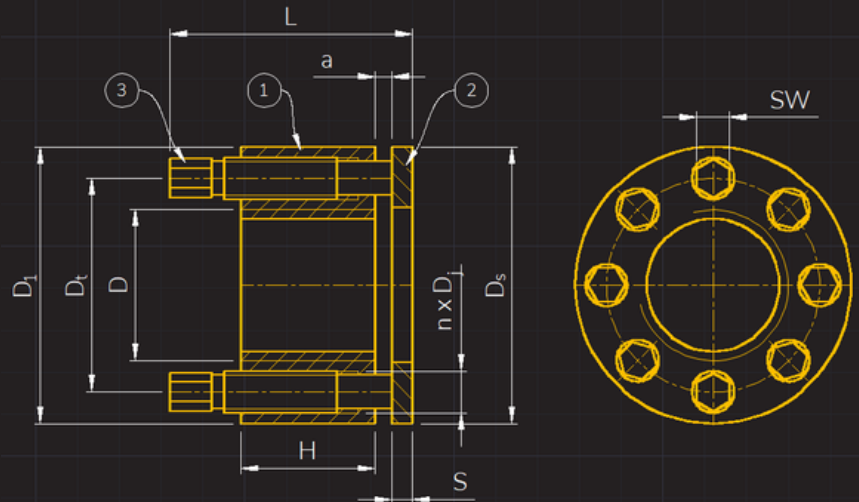

- 1 - korpus nakrętki
 2 - pierścień oporowy
 3 - śruba robocza

	D	D1	H	DT	DJ	n	SW	a	DS	S	L	waga	Mnom	Fnom
	[mm]						[szt]	[mm]					[kg]	[Nm]
PC-M16x2-Y	M16	34	16	25	M6	6	5	6	32	3	33	0.12	14	110
PC-M20x2.5-Y	M20	38	17	29	M6	8	5	5	38	4	34	0.15	14	145
PC-M22x2.5-Y	M22	41	17	31	M6	8	5	5	41	4	34	0.17	14	145
PC-M24x3-Y	M24	47	24	36	M8x1	6	6	6	47	4	44	0.30	36	215
PC-M27x3-Y	M27	51	24	39	M8x1	8	6	6	50	5	45	0.37	36	285
PC-M30x3.5-Y	M30	54	24	42	M8x1	8	6	6	53	5	45	0.38	36	285
PC-M33x3.5-Y	M33	63	32	48	M10x1.25	8	8	8	63	5	58	0.72	72	455
PC-M36x4-Y	M36	66	32	51	M10x1.25	8	8	8	66	5	58	0.79	72	455
PC-M39x4-Y	M39	72	32	54	M10x1.25	10	8	8	70	5	58	0.97	72	570
PC-M42x4.5-Y	M42	76	32	57	M10x1.25	12	8	8	73	5	58	1.10	72	685
PC-M45x4.5-Y	M45	84	38	63	M12x1.25	10	10	10	81	6	68	1.26	131	875
PC-M48x5-Y	M48	85	38	66	M12x1.25	10	10	10	85	6	68	1.54	131	875
PC-M52x5-Y	M52	94	38	70	M12x1.25	12	10	10	90	6	68	1.80	131	1050
PC-M56x5.5-Y	M56	98	38	74	M12x1.25	12	10	10	94	6	68	1.93	131	1050
PC-M60x5.5-Y	M60	109	59	83	M16x1.5	10	14	13	106	8	99	3.90	315	1580
PC-M64x6-Y	M64	113	59	87	M16x1.5	10	14	13	112	8	99	4.10	315	1580
PC-M68x6-Y	M68	117	59	91	M16x1.5	12	14	13	117	8	99	4.30	315	1900
PC-M72x6-Y	M72	121	59	95	M16x1.5	12	14	13	120	8	99	4.50	315	1900
PC-M76x6-Y	M76	132	61	102	M16x1.5	16	14	11	127	8	99	5.60	315	2530
PC-M80x6-Y	M80	133	61	103	M16x1.5	16	14	11	127	8	99	5.40	315	2530
PC-M85x6-Y	M85	139	61	108	M16x1.5	16	14	11	137	8	99	5.80	315	2530
PC-M90x6-Y	M90	158	81	119	M20x1.5	12	17	14	151	10	125	10.30	645	3150
PC-M100x6-Y	M100	168	81	129	M20x1.5	14	17	14	160	10	125	11.10	645	3670
PC-M110x6-Y	M110	178	81	139	M20x1.5	16	17	14	172	10	125	12.10	645	4200
PC-M120x6-Y	M120	189	81	149	M20x1.5	18	17	14	179	10	125	13.10	645	4700
PC-M125x6-Y	M125	194	81	154	M20x1.5	18	17	14	190	10	125	13.70	645	4700
PC-M130x6-Y	M130	205	94	159	M20x1.5	20	17	16	202	10	140	17.60	645	5250
PC-M140x6-Y	M140	215	94	169	M20x1.5	22	17	16	215	10	140	18.80	645	5750
PC-M150x6-Y	M150	225	94	179	M20x1.5	22	17	16	225	12	142	20.10	645	5750
PC-M160x6-Y	M160	235	107	189	M20x1.5	24	17	23	234	12	162	24.50	645	6300

D - gwint | D1 - śr. zewnętrzna | H - wysokość nakrętki | DT - śr. podziałowa | DJ - gwint śruby roboczej | n - ilość śrub roboczych | SW - szerokość 6-kąta | a - szczelina | DS - śr. pierścienia oporowego | S - grubość pierścienia oporowego | L - wysokość całkowita | Mnom - moment dokręcania śrub roboczych | Fnom - siła napinająca połączenie

zamiennik nakrętek sześciokątnych powyżej M100

- naprężenia w rdzeniu śruby $\sim 80 \div 270 \text{ N/mm}^2$
- temp. pracy $-10 \div +250^\circ\text{C}$
- możliwe inne wykonania i zarysy gwintów

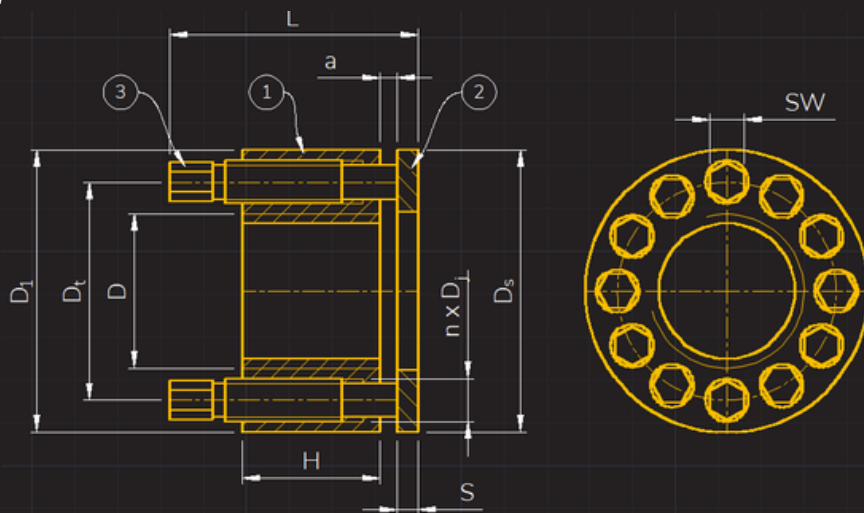

- 1 - korpus nakrętki
 2 - pierścień oporowy
 3 - śruba robocza

	D	D1	H	DT	DJ	n	SW	a	DS	S	L	waga	Mnom	Fnom
	[mm]					[szt]	[mm]					[kg]	[Nm]	[kN]
PG-M110x6-R2	M110	164	61	133	M16x1.5	16	14	11	172	10	101	7.00	215	1740
PG-M120x6-R2	M120	177	61	143		18		11	179	10	101	7.90	215	1960
PG-M125x6-R2	M125	182	61	148		18		11	190	10	101	8.25	215	1960
PG-M130x6-R2	M130	186	81	153		20		14	190	10	124	10.50	240	2420
PG-M140x6-R2	M140	196	81	163		20		14	202	10	124	11.00	240	2420
PG-M150x6-R2	M150	205	81	173		24		14	215	10	124	11.75	240	2930
PG-M160x6-R2	M160	215	81	183		24		14	227	12	126	12.75	240	2930
PG-M170x6-R2	M170	225	81	193		24		14	225	12	126	13.00	240	2930
PG-M180x6-R2	M180	235	81	203		24		14	235	12	126	13.50	240	2930
PG-M190x6-R2	M190	245	81	213		24		14	245	12	126	14.25	240	2930
PG-M200x6-R2	M200	255	81	223		24		14	255	12	126	14.75	240	2930
PG-M210x6-R2	M210	265	81	233		24		14	265	12	126	15.50	240	2930
PG-M220x6-R2	M220	275	81	243		24		14	275	12	126	16.00	240	2930
PG-M230x6-R2	M230	285	81	253		24		14	285	12	126	16.75	240	2930
PG-M240x6-R2	M240	295	81	263		24		14	295	12	126	17.25	240	2930
PG-M250x6-R2	M250	305	81	273		24		14	305	12	126	18.00	240	2930

D - gwint | D1 - śr. zewnętrzna | H - wysokość nakrętki | DT - śr. podziałowa | DJ - gwint śruby roboczej | n - ilość śrub roboczych | SW - szerokość 6-kąta | a - szczelina | DS - śr. pierścienia oporowego | S - grubość pierścienia oporowego | L - wysokość całkowita | Mnom - moment dokręcania śrub roboczych | Fnom - siła napinająca połączenie

do mocowania elementów w połączeniach ruchomych

- temp. pracy $-10 \div +250^{\circ}\text{C}$
- możliwe inne wykonania i zarysy gwintów

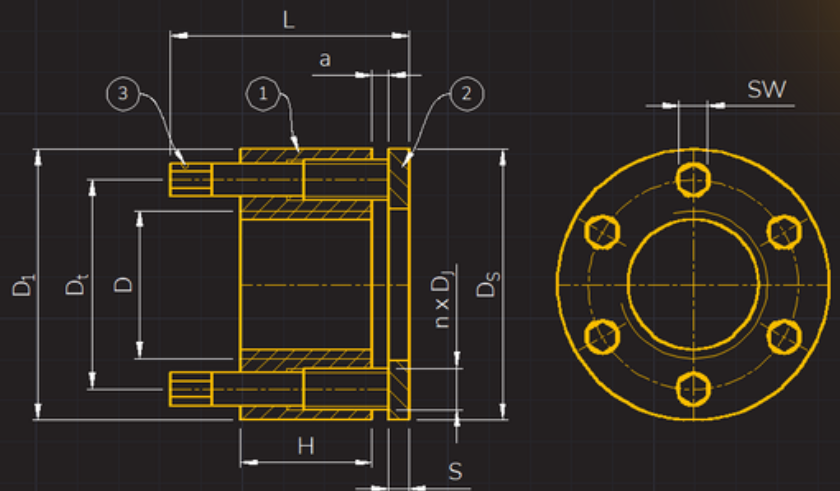

- 1 - korpus nakrętki
 2 - pierścień oporowy
 3 - śruba robocza

	D	D1	H	DT	DJ	n	SW	a	DS	S	L	waga	Mnom	Fnom
	[mm]					[szt]	[mm]					[kg]	[Nm]	[kN]
PM-M16x2-R	M16	34	16	25	M6x0.75	4	4	2	32	3	27	0.10	11	59
PM-M20x2.5-R	M20	38	16	29	M6x0.75	6	4	2	38	4	28	0.15	11	89
PM-M22x2.5-R	M22	41	16	31	M6x0.75	6	4	2	41	4	28	0.15	11	89
PM-M24x3-R	M24	44	16	33	M6x0.75	8	4	2	43	4	28	0.15	11	120
PM-M27x3-R	M27	50	24	39	M8x1	6	6	6	50	5	42	0.30	26	155
PM-M30x3.5-R	M30	53	24	42	M8x1	6	6	6	53	5	42	0.35	26	155
PM-M33x3.5-R	M33	59	24	45	M8x1	8	6	6	59	5	42	0.45	26	210
PM-M36x4-R	M36	66	32	51	M10x1.25	6	7	11	66	5	56	0.70	46	225
PM-M39x4-R	M39	70	32	54	M10x1.25	8	7	11	70	5	56	0.80	46	300
PM-M42x4.5-R	M42	75	32	57	M10x1.25	8	7	11	73	5	56	0.90	46	300
PM-M45x4.5-R	M45	83	38	63	M12x1.25	8	9	10	81	6	64	1.35	94	510
PM-M48x5-R	M48	85	38	66	M12x1.25	8	9	10	85	6	64	1.40	94	510
PM-M52x5-R	M52	91	38	70	M12x1.25	8	9	10	90	6	64	1.55	94	510
PM-M56x5.5-R	M56	96	38	74	M12x1.25	8	9	10	94	6	64	1.70	94	510
PM-M60x5.5-R	M60	102	38	78	M12x1.25	10	9	10	100	6	64	1.90	94	640
PM-M64x6-R	M64	113	53	87	M16x1.5	8	12	12	112	8	87	3.40	225	920
PM-M68x6-R	M68	117	53	91	M16x1.5	8	12	12	117	8	87	3.55	225	920
PM-M72x6-R	M72	120	56	95	M16x1.5	8	12	9	120	8	87	3.70	225	920
PM-M76x6-R	M76	132	56	100	M16x1.5	12	12	9	127	8	87	4.65	225	1370
PM-M80x6-R	M80	132	56	103	M16x1.5	12	12	9	127	8	87	4.40	225	1370
PM-M85x6-R	M85	137	56	108	M16x1.5	12	12	9	137	8	87	4.70	225	1370
PM-M90x6-R	M90	145	59	113	M16x1.5	16	12	13	137	8	94	5.45	225	1830
PM-M100x6-R	M100	157	61	123	M16x1.5	16	12	11	151	10	96	6.45	225	1830
PM-M110x6-R	M110	177	79	139	M20x1.5	12	16	9	172	10	112	10.75	465	2290
PM-M120x6-R	M120	189	81	149	M20x1.5	16	16	7	179	10	112	12.00	465	3050
PM-M125x6-R	M125	194	81	154	M20x1.5	16	16	7	190	10	112	12.50	465	3050

D - gwint | D1 - śr. zewnętrzna | H - wysokość nakrętki | DT - śr. podziałowa | DJ - gwint śruby roboczej | n - ilość śrub roboczych | SW - szerokość 6-kąta | a - szczelina | DS - śr. pierścienia oporowego | S - grubość pierścienia oporowego | L - wysokość całkowita | Mnom - moment dokręcania śrub roboczych | Fnom - siła napinająca połączenie

do mocowania elementów w połączeniach ruchowych

- temp. pracy $-10 \div +250^{\circ}\text{C}$
- możliwe inne wykonania i zarysy gwintów

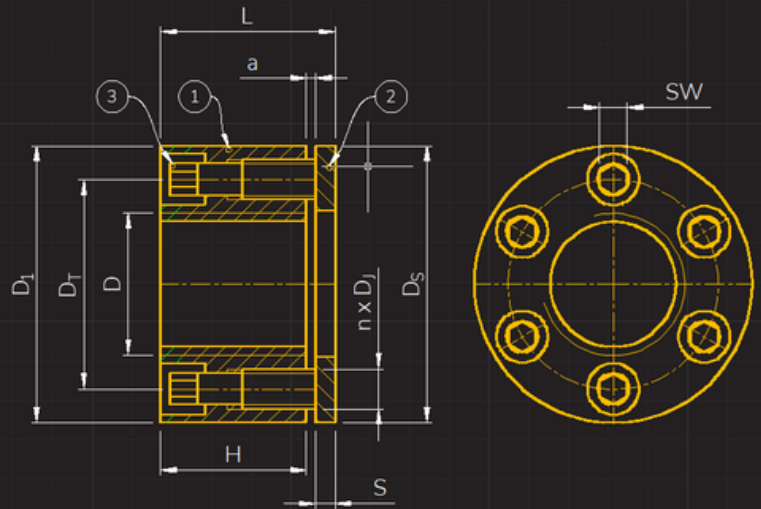

- 1 - korpus nakrętki
 2 - pierścień oporowy
 3 - śruba robocza

	D	D1	H	DT	DJ	n	SW	a	DS	S	L	waga	Mnom	Fnom
	[mm]					[szt]	[mm]					[kg]	[Nm]	[kN]
PM-M20x2.5-RA	M20	40	20	30	M6x0.75	8	4	3	39	5	25	0.16	10	105
PM-M22x2.5-RA	M22	44	20	33	M6x0.75	8	4	3	44	5	25	0.20	10	105
PM-M24x3-RA	M24	48	24	36	M6x0.75	10	4	3	48	5	29	0.28	10	135
PM-M27x3-RA	M27	54	27	41	M8x1	8	6	3	53	6	33	0.37	26	210
PM-M30x3.5-RA	M30	60	27	45	M8x1	8	6	3	60	6	33	0.48	26	210
PM-M33x3.5-RA	M33	66	33	50	M8x1	10	6	5	63	6	39	0.68	26	260
PM-M36x4-RA	M36	72	38	54	M10x1.25	8	7	6	70	8	46	0.98	46	300
PM-M39x4-RA	M39	78	38	59	M10x1.25	10	7	6	76	8	46	1.15	46	375
PM-M42x4.5-RA	M42	84	42	63	M10x1.25	12	7	6	82	8	50	1.50	46	450
PM-M45x4.5-RA	M45	90	45	68	M12x1.25	8	9	6	90	10	55	1.85	95	510
PM-M48x5-RA	M48	96	48	72	M12x1.25	10	9	8	95	10	58	2.18	95	640
PM-M52x5-RA	M52	104	48	78	M12x1.25	12	9	8	104	10	58	2.60	100	810
PM-M56x5.5-RA	M56	112	58	84	M12x1.25	12	9	8	112	10	68	3.57	100	810
PM-M60x5.5-RA	M60	120	64	90	M16x1.5	10	12	9	120	12	76	4.60	225	1140
PM-M64x6-RA	M64	128	64	96	M16x1.5	10	12	9	128	12	76	5.35	225	1140
PM-M68x6-RA	M68	136	70	102	M16x1.5	12	12	9	136	12	82	6.40	225	1370
PM-M72x6-RA	M72	144	70	108	M16x1.5	12	12	8	144	12	82	7.30	225	1370
PM-M76x6-RA	M76	152	80	114	M16x1.5	14	12	8	152	12	92	9.00	225	1600
PM-M80x6-RA	M80	160	80	120	M16x1.5	14	12	14	160	12	92	10.10	225	1600
PM-M90x6-RA	M90	170	86	130	M16x1.5	16	12	9	170	12	98	11.70	225	1830
PM-M100x6-RA	M100	190	102	145	M20x1.5	12	16	10	190	16	118	17.40	470	2310
PM-M110x6-RA	M110	209	102	160	M20x1.5	14	16	10	209	16	118	21.10	470	2690
PM-M120x6-RA	M120	228	102	174	M20x1.5	14	16	10	228	16	118	25.50	470	2690
PM-M125x6-RA	M125	238	102	181	M20x1.5	16	16	10	238	16	118	27.70	470	3070

D - gwint | D1 - śr. zewnętrzna | H - wysokość nakrętki | DT - śr. podziałowa | DJ - gwint śruby roboczej | n - ilość śrub roboczych | SW - szerokość 6-kąta | a - szczelina | DS - śr. pierścienia oporowego | S - grubość pierścienia oporowego | L - wysokość całkowita | Mnom - moment dokręcania śrub roboczych | Fnom - siła napinająca połączenie

do mocowania elementów w połączeniach ruchomych

- naprężenia w rdzeniu śruby $\sim 450 \div 700 \text{ N/mm}^2$
- temp. pracy $-10 \div +250^\circ\text{C}$
- możliwe inne wykonania i zarysy gwintów

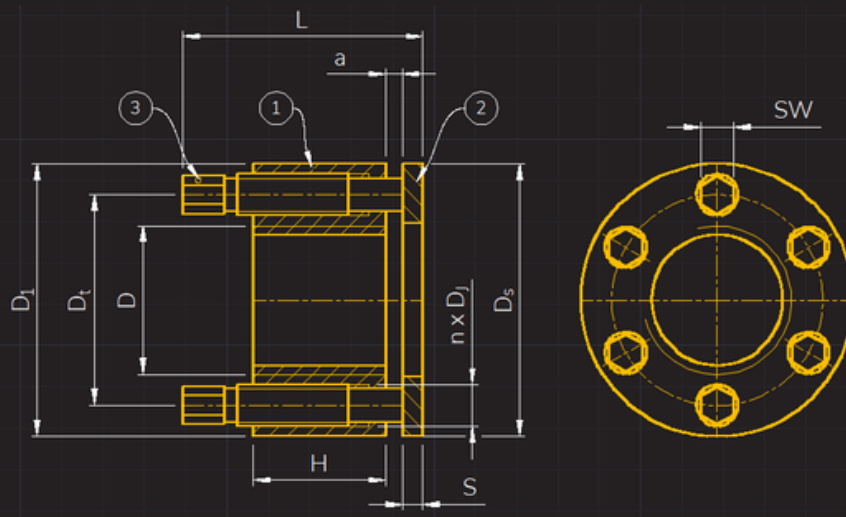

- 1 - korpus nakrętki
 2 - pierścień oporowy
 3 - śruba robocza

	D	D1	H	DT	DJ	n	SW	a	DS	S	L	waga	Mnom	Fnom
	[mm]					[szt]	[mm]					[kg]	[Nm]	[kN]
PM-M16x2-T	M16	34	16	25	M6	4	5	6	32	3	33	0.11	14	73
PM-M20x2.5-T	M20	38	16	29	M6	6	5	6	38	4	34	0.14	14	110
PM-M22x2.5-T	M22	41	16	31	M6	6	5	6	41	4	34	0.16	14	110
PM-M24x3-T	M24	44	16	33	M6	8	5	6	43	4	34	0.19	14	145
PM-M27x3-T	M27	50	24	39	M8x1	6	6	6	50	5	45	0.35	36	214
PM-M30x3.5-T	M30	53	24	42	M8x1	6	6	6	53	5	45	0.37	36	214
PM-M33x3.5-T	M33	59	24	45	M8x1	8	6	6	59	5	45	0.48	36	285
PM-M36x4-T	M36	66	32	51	M10x1.25	6	8	8	66	5	58	0.76	72	343
PM-M39x4-T	M39	70	32	54	M10x1.25	8	8	8	70	5	58	0.90	72	457
PM-M42x4.5-T	M42	75	32	57	M10x1.25	8	8	8	73	5	58	1.01	72	457
PM-M45x4.5-T	M45	83	38	63	M12x1.25	8	10	10	81	6	58	1.23	131	700
PM-M48x5-T	M48	85	38	66	M12x1.25	8	10	10	85	6	58	1.50	131	700
PM-M52x5-T	M52	91	38	70	M12x1.25	8	10	10	90	6	58	1.64	131	700
PM-M56x5.5-T	M56	98	38	74	M12x1.25	10	10	10	94	6	58	1.96	131	875
PM-M60x5.5-T	M60	102	38	78	M12x1.25	10	10	10	100	6	58	2.04	131	875
PM-M64x6-T	M64	113	53	87	M16x1.5	8	14	12	112	8	92	3.65	315	1270
PM-M68x6-T	M68	117	53	91	M16x1.5	8	14	12	117	8	92	3.85	315	1270
PM-M72x6-T	M72	120	56	95	M16x1.5	8	14	9	120	8	92	4.00	315	1270
PM-M76x6-T	M76	132	56	100	M16x1.5	12	14	9	127	8	92	5.10	315	1900
PM-M80x6-T	M80	132	56	103	M16x1.5	12	14	9	127	8	92	4.80	315	1900
PM-M85x6-T	M85	137	56	108	M16x1.5	12	14	9	137	8	92	5.10	315	1900
PM-M90x6-T	M90	145	59	113	M16x1.5	16	14	13	137	8	99	6.00	315	2530
PM-M100x6-T	M100	157	51	123	M16x1.5	16	14	11	151	10	101	7.00	315	2530
PM-M110x6-T	M110	177	79	139	M20x1.5	12	17	16	172	10	125	11.40	645	3150
PM-M120x6-T	M120	189	81	149	M20x1.5	16	17	14	179	10	125	13.00	645	4200
PM-M125x6-T	M125	194	81	154	M20x1.5	16	17	14	190	10	125	13.50	645	4200
PM-M130x6-T	M130	205	94	159	M20x1.5	18	17	16	202	10	140	17.50	645	4700
PM-M140x6-T	M140	215	94	169	M20x1.5	20	17	16	215	10	140	18.70	645	5250
PM-M150x6-T	M150	225	94	179	M20x1.5	20	17	16	225	12	142	20.00	645	5250
PM-M160x6-T	M160	234	107	189	M20x1.5	24	17	23	234	12	162	24.10	645	6300

D - gwint | D1 - śr. zewnętrzna | H - wysokość nakrętki | DT - śr. podziałowa | DJ - gwint śruby roboczej | n - ilość śrub roboczych | SW - szerokość 6-kąta | a - szczelina | DS - śr. pierścienia oporowego | S - grubość pierścienia oporowego | L - wysokość całkowita | Mnom - moment dokręcania śrub roboczych | Fnom - siła napinająca połączenie

zamiennik nakrętek sześciokątnych - klasa własności 4

- naprężenia w rdzeniu śruby $\sim 150 \div 220 \text{ N/mm}^2$
- temp. pracy $-10 \div +250^\circ\text{C}$
- możliwe inne wykonania i zarysy gwintów
- tylko 6 śrub roboczych

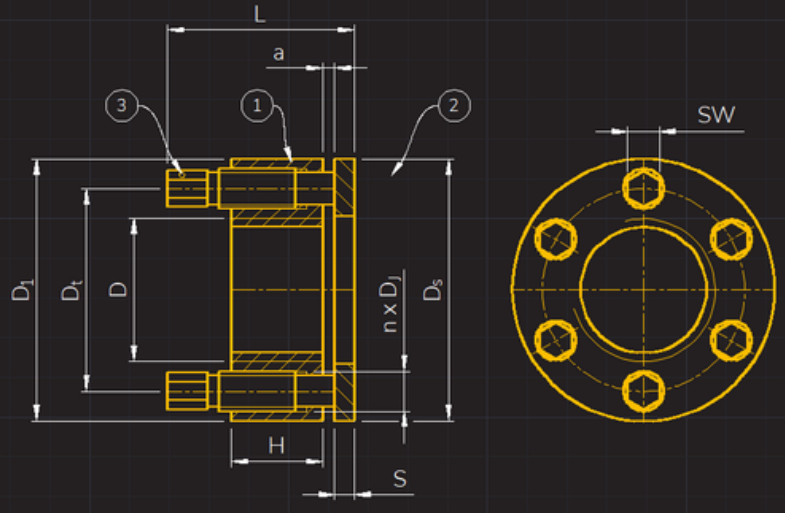

- 1 - korpus nakrętki
 2 - pierścień oporowy
 3 - śruba robocza

	D	D1	H	DT	DJ	n	SW	a	DS	S	L	waga	Mnom	Fnom
	[mm]					[szt]	[mm]					[kg]	[Nm]	[kN]
PM-M36x4-T	M36	57	17	45	M6x1	6	5	5	55	6	36	0.30	14	110
PM-M39x4-T	M39	60	17	48	M6x1		5	5	59	6	36	0.30	14	110
PM-M42x4.5-T	M42	70	22	54	M8x1		6	8	70	6	46	0.55	36	215
PM-M45x4.5-T	M45	73	22	57	M8x1		6	8	69	6	46	0.55	36	215
PM-M48x5-T	M48	76	24	60	M8x1		6	6	76	6	46	0.65	36	215
PM-M52x5-T	M52	80	24	64	M8x1		6	6	78	6	46	0.70	36	215
PM-M56x5.5-T	M56	91	28	71	M10x1.25		8	7	86	6	52	1.10	71	340
PM-M60x5.5-T	M60	95	28	75	M10x1.25		8	7	94	6	52	1.20	71	340
PM-M64x6-T	M64	99	32	79	M10x1.25		8	8	98	6	58	1.35	71	340
PM-M68x6-T	M68	103	32	83	M10x1.25		8	8	100	6	58	1.40	71	340
PM-M72x6-T	M72	113	38	89	M12x1.25		10	10	112	6	68	2.10	130	520
PM-M76x6-T	M76	117	38	93	M12x1.25		10	10	116	8	70	2.30	130	520
PM-M80x6-T	M80	121	38	97	M12x1.25		10	10	120	8	70	2.40	130	520
PM-M85x6-T	M85	140	45	108	M16x1.5		14	11	137	8	83	4.15	260	790
PM-M90x6-T	M90	145	45	113	M16x1.5		14	11	137	8	83	4.30	260	790
PM-M100x6-T	M100	155	45	123	M16x1.5		14	11	151	8	83	4.70	260	790

D - gwint | D1 - śr. zewnętrzna | H - wysokość nakrętki | DT - śr. podziałowa | DJ - gwint śruby roboczej | n - ilość śrub roboczych | SW - szerokość 6-kąta | a - szczelina | DS - śr. pierścienia oporowego | S - grubość pierścienia oporowego | L - wysokość całkowita | Mnom - moment dokręcania śrub roboczych | Fnom - siła napinająca połączenie

do ustalania położenia łożysk

- temp. pracy $-10 \div +250^{\circ}\text{C}$
- możliwe inne wykonania i zarysy gwintów

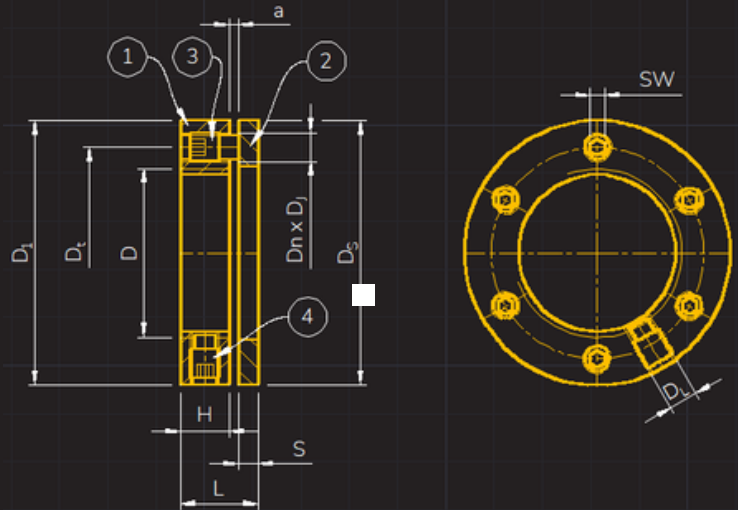

- 1 - korpus nakrętki
 2 - pierścień oporowy
 3 - śruba robocza
 4 - wkręt dociskowy

	D	D1	H	DT	DJ	n	SW	a	DS	S	DL	L	waga	Mnom	Fnom
	[mm]					[szt]	[mm]					[kg]	[Nm]	[kN]	
PN-M30x1.5-M	M30x1.5	50	10	39	M6x0.75	6	3	4	50	3	M6x0.75	13	0.10	2.5	39
PN-M35x1.5-M	M35x1.5	55	10	44	M6x0.75	6	3	4	55	3	M6x0.75	13	0.15	2.5	39
PN-M40x1.5-M	M40x1.5	71	12	52	M8x1	6	4	4	71	4	M8x1	16	0.35	6	70
PN-M45x1.5-M	M45x1.5	75	12	57	M8x1	6	4	4	75	4	M8x1	16	0.35	6	70
PN-M50x1.5-M	M50x1.5	78	12	62	M8x1	6	4	4	78	4	M8x1	16	0.35	6	70
PN-M55x2-M	M55x2	84	12	67	M8x1	6	4	4	84	4	M8x1	16	0.40	6	70
PN-M60x2-M	M60x2	90	12	72	M8x1	6	4	4	90	4	M8x1	16	0.45	6	70
PN-M65x2-M	M65x2	94	12	77	M8x1	6	4	4	94	4	M8x1	16	0.45	6	70
PN-M70x2-M	M70x2	100	12	82	M8x1	6	4	4	100	4	M8x1	16	0.50	6	70
PN-M75x2-M	M75x2	104	12	87	M8x1	6	4	4	104	4	M8x1	16	0.50	6	70
PN-M80x2-M	M80x2	109	18	95	M10x1.25	6	5	6	109	5	M8x1	23	0.75	10	95
PN-M85x2-M	M85x2	114	18	100	M10x1.25	6	5	6	114	5	M8x1	23	0.80	10	95
PN-M90x2-M	M90x2	119	18	105	M10x1.25	6	5	6	119	5	M8x1	23	0.85	10	95
PN-M95x2-M	M95x2	126	19	110	M10x1.25	8	5	6	126	5	M8x1	24	1.00	10	125
PN-M100x2-M	M100x2	131	19	115	M10x1.25	8	5	6	131	5	M8x1	24	1.05	10	125
PN-M105x2-M	M105x2	138	19	120	M10x1.25	8	5	6	138	5	M8x1	24	1.15	12	150
PN-M110x2-M	M110x2	150	22	128	M12x1.25	8	6	8	150	6	M10x1.25	28	1.75	19	205
PN-M115x2-M	M115x2	155	22	133	M12x1.25	8	6	8	155	6	M10x1.25	28	1.85	19	205
PN-M120x2-M	M120x2	159	23	138	M12x1.25	8	6	8	159	6	M10x1.25	29	1.90	19	205
PN-M125x2-M	M125x2	164	23	143	M12x1.25	8	6	8	164	6	M10x1.25	29	2.00	19	205
PN-M130x2-M	M130x2	171	24	148	M12x1.25	12	6	8	171	6	M10x1.25	30	2.20	16	260
PN-M135x2-M	M135x2	176	24	153	M12x1.25	12	6	8	176	6	M10x1.25	30	2.30	16	260
PN-M140x2-M	M140x2	182	24	158	M12x1.25	12	6	8	182	6	M10x1.25	30	2.45	16	260
PN-M145x2-M	M145x2	186	24	163	M12x1.25	12	6	8	186	6	M10x1.25	30	2.45	16	260
PN-M150x2-M	M150x2	190	25	168	M12x1.25	12	6	8	190	6	M10x1.25	31	2.55	16	260
PN-M155x3-M	M155x3	195	25	173	M12x1.25	12	6	8	195	8	M10x1.25	33	2.80	16	260
PN-M160x3-M	M160x3	213	27	183	M16x1.5	8	8	8	213	8	M12x1.25	35	4.25	39	320

większe rozmiary na życzenia

D - gwint | D1 - śr. zewnętrzna | H - wysokość nakrętki | DT - śr. podziałowa | DJ - gwint śruby roboczej | n - ilość śrub roboczych | SW - szerokość 6-kąta | a - szczelina | DS - śr. pierścienia oporowego | S - grubość pierścienia oporowego | L - wysokość całkowita | Mnom - moment dokręcania śrub roboczych | Fnom - siła napinająca połączenie

zamiennik śrub z łbem szesciokątnym

- naprężenia w rdzeniu śruby ~400 ÷ 650 N/mm²
- temp. pracy -10 ÷ +250°C
- możliwe inne wykonania oraz zarysy gwintów

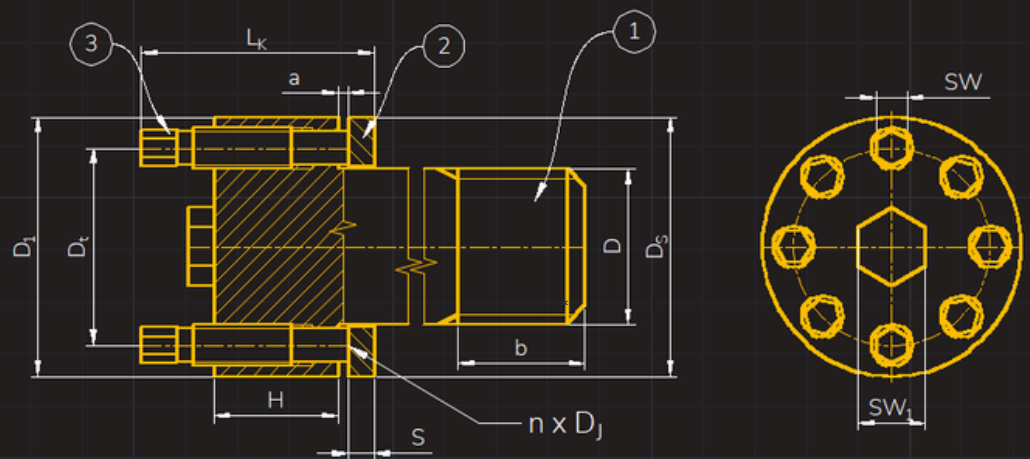

- 1 - korpus śruby
 2 - pierścien oporowy
 3 - śruba robocza

	D	D1	H	DT	DJ	n	SW	a	DS	S	SW1	Lk	waga L=100	Mnom	Fnom
	[mm]					[szt]	[mm]					[kg]	[Nm]	[kN]	
PS-M16x2-B8	M16	31	18	22	M6	4	5	4	30	3	8	32	0.28	14	73
PS-M20x2.5-B8	M20	35	18	26	M6	6	5	4	35	4	10	33	0.42	14	109
PS-M24x3-B8	M24	41	18	30	M6	8	5	4	41	4	10	33	0.60	14	146
PS-M27x3-B8	M27	45	23	35	M8x1	6	6	7	45	5	13	45	0.81	32	190
PS-M30x3.5-B8	M30	50	23	38	M8x1	6	6	7	50	5	13	45	1.00	36	214
PS-M33x3.5-B8	M33	57	28	43	M10x1.25	6	8	7	57	5	17	52	1.40	60	285
PS-M36x4-B8	M36	60	28	46	M10x1.25	6	8	7	60	5	19	52	1.60	70	333
PS-M39x4-B8	M39	63	28	49	M10x1.25	8	8	7	63	5	19	52	1.80	64	406
PS-M42x4.5-B8	M42	66	28	52	M10x1.25	8	8	7	66	5	19	52	2.00	72	457
PS-M45x4.5-B8	M45	75	37	57	M12x1.25	8	10	7	75	6	19	64	2.80	100	535
PS-M48x5-B8	M48	78	37	60	M12x1.25	8	10	7	78	6	24	64	3.10	113	605
PS-M52x5-B8	M52	82	37	64	M12x1.25	10	10	7	82	6	30	64	3.60	110	735
PS-M56x5.5-B8	M56	86	37	68	M12x1.25	10	10	7	86	6	30	64	4.30	125	835
PS-M60x5.5-B8	M60	90	37	72	M12x1.25	12	10	7	90	6	30	64	4.50	123	985
PS-M64x6-B8	M64	103	46	80	M16x1.5	8	14	10	103	8	30	83	6.20	235	950
PS-M68x6-B8	M68	107	46	84	M16x1.5	8	14	10	107	8	36	83	7.00	270	1090
PS-M72x6-B8	M72	111	46	88	M16x1.5	10	14	10	111	8	36	83	7.50	245	1230
PS-M76x6-B8	M76	116	46	92	M16x1.5	12	14	10	116	8	36	83	8.40	230	1390
PS-M80x6-B8	M80	120	56	96	M16x1.5	12	14	9	120	8	36	92	10.10	260	1570
PS-M90x6-B8	M90	130	56	106	M16x1.5	16	14	9	130	8	46	92	12.50	250	2010
PS-M100x6-B8	M100	148	60	120	M20x1.5	12	17	10	148	10	55	99	16.70	520	2540
PS-M110x6-B8	M110	158	60	130	M20x1.5	14	17	10	158	10	55	99	19.50	500	2850
PS-M120x6-B8	M120	170	64	140	M20x1.5	16	17	12	170	10	55	105	23.30	520	3380
PS-M125x6-B8	M125	175	64	145	M20x1.5	16	17	12	175	10	55	105	24.80	560	3650
PS-M130x6-B8	M130	180	76	150	M20x1.5	18	17	12	180	10	65	118	34.90	540	3950
PS-M140x6-B8	M140	190	76	160	M20x1.5	20	17	12	190	10	65	118	33.30	560	4550
PS-M150x6-B8	M150	200	76	170	M20x1.5	20	17	12	200	10	65	118	37.20	600	4880
PS-M160x6-B8	M160	210	76	180	M20x1.5	20	17	12	210	10	65	118	40.20	650	5280

*Długość całkowita śruby oraz długość gwintu do ustalenia

D - gwint | D1 - śr. zewnętrzna | H - wysokość nakrętki | DT - śr. podziałowa | DJ - gwint śruby roboczej | n - ilość śrub roboczych | SW - szerokość 6-kąta | a - szczelina | DS - śr. pierścienia oporowego | S - grubość pierścienia oporowego | Lk - wysokość całkowita łba | Mnom - moment dokręcania śrub roboczych | Fnom - siła napinająca połączenie

zamiennik śrub z łbem szesciokątnym

- naprężenia w rdzeniu śruby $\sim 500 \div 850 \text{ N/mm}^2$
- temp. pracy $-10 \div +250^\circ\text{C}$
- możliwe inne wykonania oraz zarysy gwintów

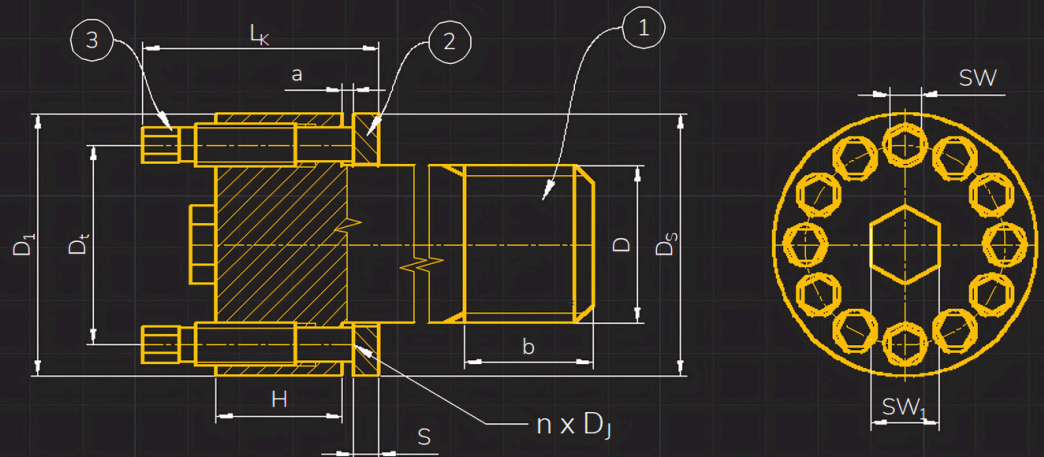

- 1 - korpus śruby
 2 - pierścień oporowy
 3 - śruba robocza

	D	D1	H	DT	DJ	n	SW	a	DS	S	SW1	Lk	waga L=100	Mnom	Fnom
	[mm]						[szt]	[mm]					[kg]	[Nm]	[kN]
PS-M20x2.5-B8	M20	35	18	26	M6	8	5	4	35	4	10	33	0.42	14	146
PS-M24x3-B8	M24	43	24	32	M8x1	6	6	6	43	4	10	44	0.68	34	202
PS-M27x3-B8	M27	47	24	35	M8x1	8	6	6	47	5	13	45	0.86	34	270
PS-M30x3.5-B8	M30	50	24	38	M8x1	10	6	6	50	5	13	45	1.00	32	317
PS-M33x3.5-B8	M33	57	28	43	M10x1.25	8	8	7	57	5	17	52	1.40	64	406
PS-M36x4-B8	M36	60	28	46	M10x1.25	10	8	7	60	5	19	52	1.60	64	508
PS-M39x4-B8	M39	63	28	49	M10x1.25	12	8	7	63	5	19	52	1.80	60	570
PS-M42x4.5-B8	M42	66	28	52	M10x1.25	12	8	7	66	5	19	52	2.00	68	645
PS-M45x4.5-B8	M45	75	37	57	M12x1.25	10	10	7	75	6	19	64	2.80	114	760
PS-M48x5-B8	M48	78	37	60	M12x1.25	10	10	7	78	6	24	64	3.10	128	855
PS-M52x5-B8	M52	82	37	64	M12x1.25	12	10	7	82	6	30	64	3.60	124	995
PS-M56x5.5-B8	M56	86	37	68	M12x1.25	12	10	7	86	6	30	64	4.30	124	995
PS-M60x5.5-B8	M60	90	37	72	M12x1.25	14	10	7	90	6	30	64	4.50	124	1160
PS-M64x6-B8	M64	103	46	80	M16x1.5	10	14	10	103	8	30	83	6.20	260	1310
PS-M68x6-B8	M68	107	46	84	M16x1.5	10	14	10	107	8	36	83	7.00	295	1480
PS-M72x6-B8	M72	111	56	88	M16x1.5	12	14	9	111	8	36	92	7.50	280	1690
PS-M76x6-B8	M76	116	56	92	M16x1.5	14	14	9	116	8	36	92	8.60	270	1900
PS-M80x6-B8	M80	120	56	96	M16x1.5	14	14	9	120	8	36	92	10.20	300	2110
PS-M90x6-B8	M90	139	61	110	M20x1.5	12	17	9	139	10	46	99	17.80	560	2740

*Długość całkowita śruby oraz długość gwintu do ustalenia

D - gwint | D1 - śr. zewnętrzna | H - wysokość nakrętki | DT - śr. podziałowa | DJ - gwint śruby roboczej | n - ilość śrub roboczych | SW - szerokość 6-kąta | a - szczelina | DS - śr. pierścienia oporowego | S - grubość pierścienia oporowego | Lk - wysokość całkowita łba | Mnom - moment dokręcania śrub roboczych | Fnom - siła napinająca połączenie

zamiennik nakrętek szesciokątnych niskich

- temp. pracy $-10 \div +250^{\circ}\text{C}$
- możliwe inne wykonania oraz zarysy gwintów

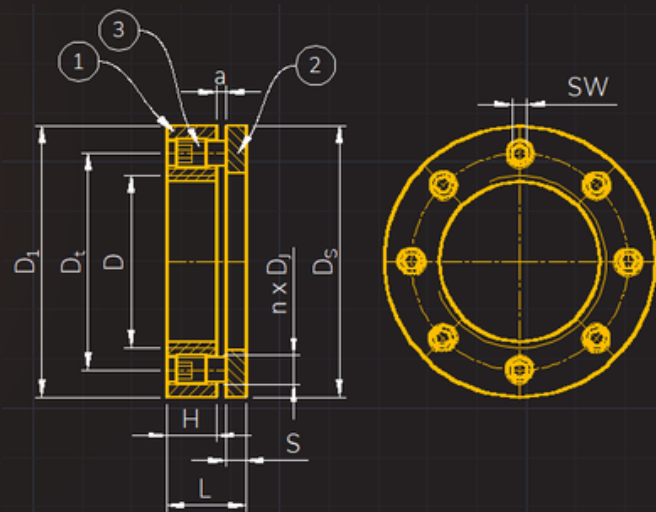

- 1 - korpus nakrętki
 2 - pierścień oporowy
 3 - śruba robocza

	D	D1	H	DT	DJ	n	SW	a	DS	S	L	waga	Mnom	Fnom
	[mm]					[szt]	[mm]					[kg]	[Nm]	[kN]
PS-M20x2.5-J	M20	43	15	32	M8x1	6	4	4	43	4	19	0.15	11	67
PS-M22x2.5-J	M22	47	16	34	M8x1	8	4	4	45	5	21	0.20	10	81
PS-M24x3-J	M24	50	16	36	M8x1	8	4	4	48	5	21	0.20	11	89
PS-M27x3-J	M27	53	16	39	M8x1	10	4	4	50	5	21	0.25	10	100
PS-M30x3.5-J	M30	60	21	45	M10x1.25	8	5	6	59	5	26	0.40	21	135
PS-M33x3.5-J	M33	63	22	48	M10x1.25	10	5	6	63	5	27	0.40	19	155
PS-M36x4-J	M36	69	28	54	M12x1.25	8	6	7	69	5	33	0.65	35	190
PS-M39x4-J	M39	75	28	57	M12x1.25	10	6	7	75	5	33	0.80	38	255
PS-M42x4.5-J	M42	81	28	60	M12x1.25	12	6	7	78	5	33	0.90	39	315
PS-M45x4.5-J	M45	84	28	63	M12x1.25	12	6	7	81	6	34	1.00	39	315
PS-M48x5-J	M48	101	31	71	M16x1.5	8	8	8	94	6	37	1.65	94	380
PS-M52x5-J	M52	101	33	75	M16x1.5	8	8	8	94	6	39	1.65	94	380
PS-M56x5.5-J	M56	113	33	79	M16x1.5	12	8	8	106	6	39	2.05	94	570
PS-M60x5.5-J	M60	117	33	83	M16x1.5	12	8	8	106	6	39	2.15	94	570
PS-M64x6-J	M64	121	33	87	M16x1.5	12	8	8	120	8	41	2.45	94	570
PS-M68x6-J	M68	138	38	97	M20x1.5	12	10	8	125	8	46	3.60	145	710
PS-M72x6-J	M72	151	38	101	M20x1.5	12	10	8	138	8	46	4.50	185	910
PS-M76x6-J	M76	151	38	105	M20x1.5	12	10	8	138	8	46	4.35	175	860
PS-M80x6-J	M80	158	38	109	M20x1.5	12	10	8	145	10	48	4.95	185	910
PS-M90x6-J	M90	170	51	125	M24x2	12	12	12	160	10	61	7.20	280	1160
PS-M100x6-J	M100	180	53	135	M24x2	12	12	12	172	10	63	7.75	280	1160
PS-M110x6-J	M110	190	59	145	M24x2	16	12	12	190	10	69	9.25	280	1550
PS-M120x6-J	M120	202	59	155	M24x2	16	12	12	202	10	69	10.25	280	1550
PS-M125x6-J	M125	205	59	160	M24x2	16	12	12	202	10	69	10.25	280	1550
PS-M130x6-J	M130	210	59	165	M24x2	16	12	12	202	10	69	10.50	280	1550
PS-M140x6-J	M140	221	59	175	M24x2	16	12	12	215	12	71	11.75	280	1550
PS-M150x6-J	M150	230	59	185	M24x2	16	12	12	225	12	71	12.25	280	1550
PS-M160x6-J	M160	240	59	195	M24x2	16	12	12	240	12	71	13.25	280	1550

D - gwint | D1 - śr. zewnętrzna | H - wysokość nakrętki | DT - śr. podziałowa | DJ - gwint śruby roboczej | n - ilość śrub roboczych | SW - szerokość 6-kąta | a - szczelina | DS - śr. pierścienia oporowego | S - grubość pierścienia oporowego | L - wysokość całkowita | Mnom - moment dokręcania śrub roboczych | Fnom - siła napinająca połączenie

zamiennik nakrętek szesciokątnych niskich - kl. własności 8

- temp. pracy $-10 \div +250^{\circ}\text{C}$
- możliwe inne wykonania oraz zarysy gwintów

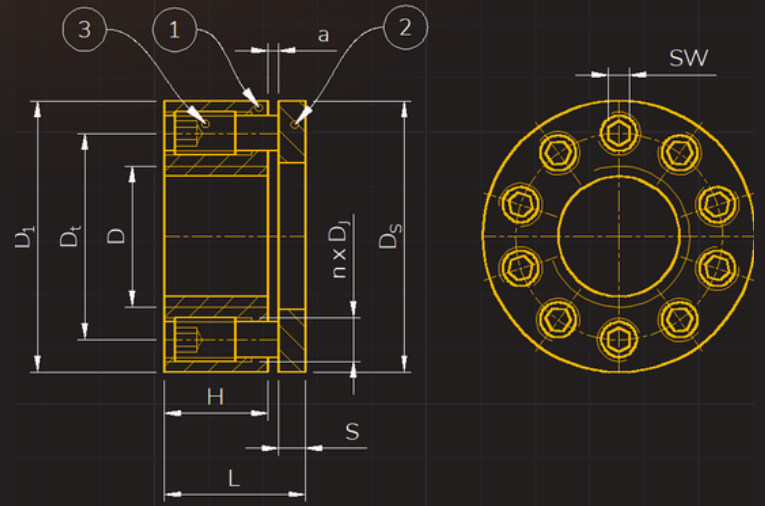

- 1 - korpus nakrętki
 2 - pierścień oporowy
 3 - śruba robocza

	D	D1	H	DT	DJ	n	SW	a	DS	S	L	waga	Mnom	Fnom
	[mm]						[szt]	[mm]					[kg]	[Nm]
PS-M20x2.5-JX	M20	44	18	32	M8x1	4	4	4	43	4	22	0.20	11	86
PS-M22x2.5-JX	M22	47	18	34	M8x1	4	4	4	45	5	23	0.25	11	86
PS-M24x3-JX	M24	50	18	36	M8x1	6	4	4	48	5	23	0.25	11	130
PS-M27x3-JX	M27	56	18	39	M8x1	8	4	4	50	5	23	0.30	11	170
PS-M30x3.5-JX	M30	63	23	45	M10x1.25	8	5	4	59	5	28	0.50	17	215
PS-M33x3.5-JX	M33	69	23	48	M10x1.25	10	5	4	63	5	28	0.60	17	270
PS-M36x4-JX	M36	74	30	54	M12x1.25	8	6	7	69	5	35	0.85	32	345
PS-M39x4-JX	M39	80	30	57	M12x1.25	10	6	7	75	5	35	0.95	30	405
PS-M42x4.5-JX	M42	88	30	60	M12x1.25	10	6	7	78	5	35	1.20	36	485
PS-M45x4.5-JX	M45	90	30	63	M12x1.25	10	6	7	81	6	36	1.25	38	510
PS-M48x5-JX	M48	101	38	71	M16x1.5	8	8	8	94	6	44	2.00	75	620
PS-M52x5-JX	M52	107	38	75	M16x1.5	10	8	8	106	6	44	2.25	68	700
PS-M56x5.5-JX	M56	113	38	79	M16x1.5	10	8	8	106	6	44	2.45	74	760
PS-M60x5.5-JX	M60	120	38	83	M16x1.5	10	8	8	106	6	44	2.75	83	860
PS-M64x6-JX	M64	126	42	87	M16x1.5	12	8	8	120	8	50	3.40	90	1110
PS-M68x6-JX	M68	145	46	97	M20x1.5	12	10	8	125	8	54	4.90	130	1330
PS-M72x6-JX	M72	151	46	101	M20x1.5	12	10	8	138	8	54	5.40	135	1380
PS-M76x6-JX	M76	158	52	105	M20x1.5	12	10	8	138	8	60	6.40	185	1900
PS-M80x6-JX	M80	162	52	109	M20x1.5	12	10	8	145	10	62	6.45	185	1900
PS-M90x6-JX	M90	177	64	125	M24x2	12	12	12	160	10	74	9.55	260	2210
PS-M100x6-JX	M100	182	76	135	M24x2	14	12	12	172	10	86	11.25	275	2730
PS-M110x6-JX	M110	202	79	145	M24x2	16	12	12	190	10	89	14.50	295	3340
PS-M120x6-JX	M120	208	79	155	M24x2	16	12	12	202	10	89	14.75	295	3340
PS-M125x6-JX	M125	214	79	160	M24x2	16	12	12	202	10	89	15.25	295	3340
PS-M130x6-JX	M130	214	91	165	M24x2	18	12	12	202	10	101	16.00	295	3760
PS-M140x6-JX	M140	221	91	175	M24x2	18	12	12	215	12	103	16.75	295	3760
PS-M150x6-JX	M150	231	95	185	M24x2	20	12	12	225	12	107	18.00	290	4110
PS-M160x6-JX	M160	241	95	195	M24x2	20	12	12	240	12	107	19.25	290	4110

D - gwint | D1 - śr. zewnętrzna | H - wysokość nakrętki | DT - śr. podziałowa | DJ - gwint śruby roboczej | n - ilość śrub roboczych | SW - szerokość 6-kąta | a - szczelina | DS - śr. pierścienia oporowego | S - grubość pierścienia oporowego | L - wysokość całkowita | Mnom - moment dokręcania śrub roboczych | Fnom - siła napinająca połączenie

mocowanie elementów na stożkowych czopach wałów (DIN1448)

- temp. pracy $-10 \div +250^{\circ}\text{C}$
- możliwe inne wykonania oraz zarysy gwintów

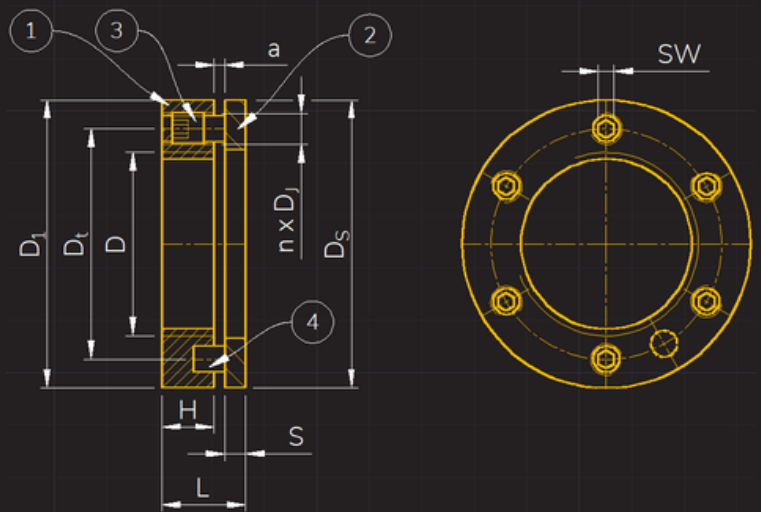

- 1 - korpus nakrętki
 2 - pierścień oporowy
 3 - śruba robocza
 4 - bolec ustalający

	DIN 1448	D	D1	H	DT	DJ	n	SW	a	DS	S	L	waga	Mnom	Fnom
	[mm]	[mm]						[szt]	[mm]				[kg]	[Nm]	[kN]
PS-45-M	Ø45	M30x2	70	20	50	M10x1.25	6	5	4	70	5	25	0.58	19	93
PS-50-M	Ø50	M36x3	75	20	55	M10x1.25	8	5	4	69	5	25	0.59	17	110
PS-55-M	Ø55	M36x3	80	20	60	M10x1.25	8	5	4	76	5	25	0.70	20	132
PS-60-M	Ø60	M42x3	90	26	66	M12x1.25	8	6	5	81	6	32	1.15	30	163
PS-65-M	Ø65	M42x3	95	26	71	M12x1.25	8	6	5	95	6	32	1.35	35	192
PS-70-M	Ø70	M48x3	100	26	76	M12x1.25	10	6	5	94	6	32	1.40	33	222
PS-75-M	Ø75	M48x3	105	26	81	M12x1.25	10	6	5	105	6	32	1.60	37	253
PS-80-M	Ø80	M56x4	108	27	84	M12x1.25	12	6	5	106	6	33	1.60	35	286
PS-85-M	Ø85	M56x4	113	27	89	M12x1.25	14	6	5	106	6	33	1.75	35	329
PS-90-M	Ø90	M64x4	133	27	98	M16x1.5	8	8	8	123	8	35	2.60	90	365
PS-95-M	Ø95	M64x4	140	27	103	M16x1.5	10	8	8	134	8	35	3.00	79	400
PS-100-M	Ø100	M72x4	147	27	105	M16x1.5	10	8	8	138	8	35	3.20	90	459
PS-110-M	Ø110	M80x4	154	31	115	M16x1.5	12	8	8	145	8	39	3.65	90	552
PS-120-M	Ø120	M90x4	184	31	129	M20x1.5	10	10	8	160	10	41	5.65	155	640
PS-130-M	Ø130	M100x4	194	34	136	M20x1.5	12	10	8	172	10	44	6.55	155	770
PS-140-M	Ø140	M100x4	214	34	146	M20x1.5	12	10	8	172	10	44	8.10	180	890
PS-150-M	Ø150	M110x4	224	36	156	M20x1.5	14	10	8	224	10	46	10.05	175	1000
PS-160-M	Ø160	M125x4	224	42	163	M20x1.5	16	10	8	202	10	52	9.90	175	1150
PS-170-M	Ø170	M125x4	233	44	173	M20x1.5	18	10	8	202	10	54	11.20	175	1290
PS-180-M	Ø180	M140x6	250	44	183	M20x1.5	20	10	8	215	10	54	12.40	180	1470
PS-190-M	Ø190	M140x6	250	55	194	M24x2	16	12	12	240	12	67	16.00	300	1650
PS-200-M	Ø200	M160x6	265	55	204	M24x2	18	12	12	240	12	67	16.40	290	1800
PS-220-M	Ø220	M160x6	304	55	224	M24x2	20	12	12	290	12	67	25.20	315	2175

D - gwint | D1 - śr. zewnętrzna | H - wysokość nakrętki | DT - śr. podziałowa | DJ - gwint śruby roboczej | n - ilość śrub roboczych | SW - szerokość 6-kąta | a - szczelina | DS - śr. pierścienia oporowego | S - grubość pierścienia oporowego | L - wysokość całkowita | Mnom - moment dokręcania śrub roboczych | Fnom - siła napinająca połączenie

zamiennik śrub z łbem walcowym

- do M60 - klasa 8.8
- powyżej M60 - 42CrMo4
- naprężenia w rdzeniu śruby
~450÷600 N/mm
- temp. pracy -10 ÷ +250°C
- możliwe inne wykonania
oraz zarysy gwintów

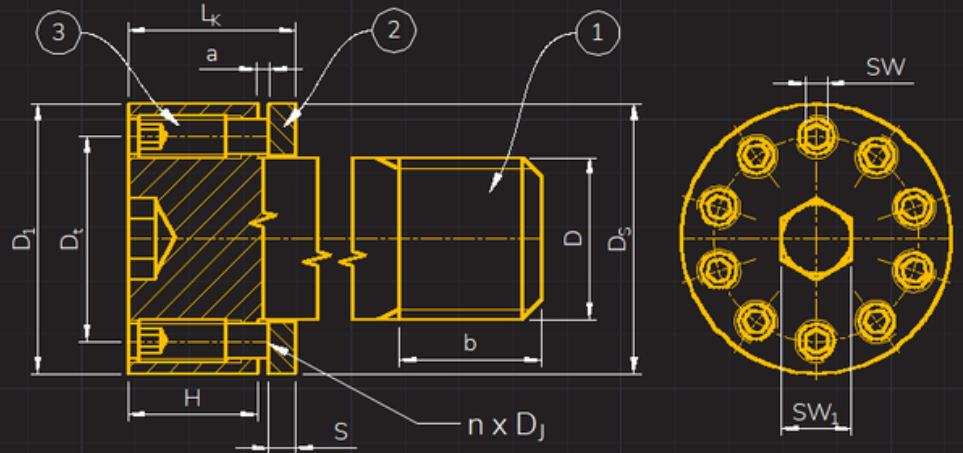

- 1 - korpus śruby
 2 - pierścień oporowy
 3 - śruba robocza

	D	D1	H	DT	DJ	n	SW	a	DS	S	SW1	Lk	waga L=100	Mnom	Fnom
	[mm]					[szt]	[mm]					[kg]	[Nm]	[kN]	
PS-M20x2.5-SJ	M20	32	17	24	M6x0.75	8	3	3	32	4	10	21	0.35	4.5	94
PS-M22x2.5-SJ	M22	35	17	26	M6x0.75	10	3	3	35	4	10	21	0.45	4.5	115
PS-M24x3-SJ	M24	38	19	28	M6x0.75	12	3	3	38	4	10	23	0.55	4.5	140
PS-M27x3-SJ	M27	41	19	31	M6x0.75	12	3	3	41	5	10	24	0.65	4.5	140
PS-M30x3.5-SJ	M30	45	23	35	M8x1	10	4	4	45	5	10	28	0.85	11	215
PS-M33x3.5-SJ	M33	50	23	38	M8x1	12	4	4	50	5	10	28	1.05	11	255
PS-M36x4-SJ	M36	55.5	27	44	M10x1.25	10	5	5	55	6	19	33	1.35	20	315
PS-M39x4-SJ	M39	59	27	47	M10x1.25	12	5	5	59	6	19	33	1.60	20	380
PS-M42x4.5-SJ	M42	63	27	50	M10x1.25	12	5	5	63	6	19	33	1.80	20	380
PS-M45x4.5-SJ	M45	69	38	55	M12x1.25	12	6	5	69	6	19	44	2.35	33	530
PS-M48x5-SJ	M48	72	38	58	M12x1.25	12	6	5	72	6	19	44	2.65	37	600
PS-M52x5-SJ	M52	76	38	62	M12x1.25	12	6	5	76	6	19	44	3.05	39	630
PS-M56x5.5-SJ	M56	84	38	66	M12x1.25	12	6	5	84	6	19	44	3.70	39	630
PS-M60x5.5-SJ	M60	88	38	70	M12x1.25	14	6	5	88	6	19	44	4.10	39	740
PS-M64x6-SJ	M64	97	51	78	M16x1.5	12	8	10	97	8	19	59	5.70	75	930
PS-M68x6-SJ	M68	104	51	82	M16x1.5	12	8	10	104	8	19	59	6.55	86	1060
PS-M72x6-SJ	M72	108	51	86	M16x1.5	14	8	10	108	8	19	59	7.15	83	1200
PS-M76x6-SJ	M76	114	51	90	M16x1.5	14	8	10	114	8	19	59	8.00	94	1360
PS-M80x6-SJ	M80	117	51	94	M16x1.5	16	8	10	117	8	19	59	8.60	90	1490
PS-M90x6-SJ	M90	131	76	108	M20x1.5	14	10	10	131	10	19	86	13.00	165	1970
PS-M100x6-SJ	M100	144	76	118	M20x1.5	14	10	10	144	10	19	86	16.25	185	2210

D - gwint | D1 - śr. zewnętrzna | H - wysokość nakrętki | DT - śr. podziałowa | DJ - gwint śruby roboczej | n - ilość śrub roboczych | SW - szerokość 6-kąta | a - szczelina | DS - śr. pierścienia oporowego | S - grubość pierścienia oporowego | Lk - wysokość całkowita łba | Mnom - moment dokręcania śrub roboczych | Fnom - siła napinająca połączenie

współpraca z elementami systemów napinających

- naprężenia w rdzeniu śruby ~450÷700 N/mm
- temp. pracy -10 ÷ +250°C
- możliwe inne wykonania oraz zarysy gwintów

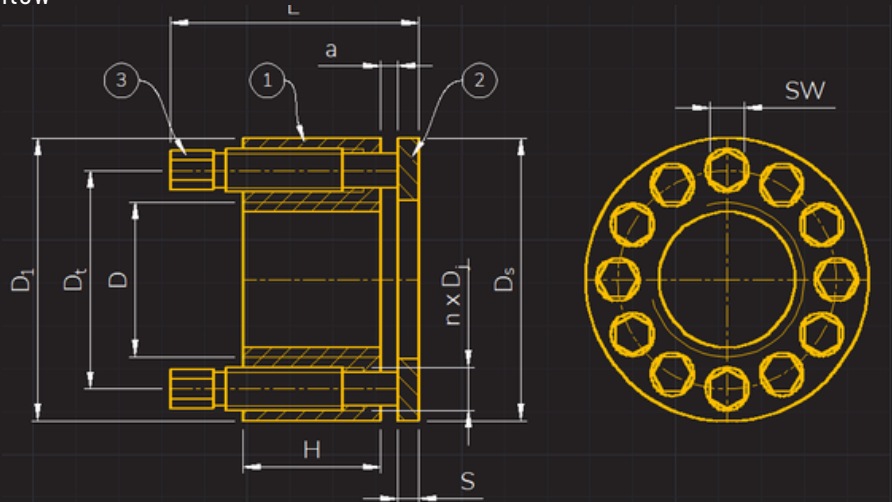

1 - korpus nakrętki
 2 - pierścień oporowy

	D	D1	H	D2	h	SW	DS	S	L	waga	Fnom	Fmax
	[mm]					[mm]				[kg]	[kN]	[kN]
PS-M20x2.5-X8	M20	35	17	30	8	27	38	4	21	0.10	110	140
PS-M24x3-X8	M24	42	20	37	10	33	45	4	24	0.15	145	187
PS-M27x3-X8	M27	47	23	40	11	36	50	5	28	0.20	214	285
PS-M30x3.5-X8	M30	52	25	43	12	39	56	5	30	0.25	214	285
PS-M33x3.5-X8	M33	57	28	47	13	42	63	6	34	0.40	285	380
PS-M36x4-X8	M36	62	31	53	14	48	69	6	37	0.50	343	457
PS-M39x4-X8	M39	66	33	56	15	51	72	6	39	0.60	457	610
PS-M42x4.5-X8	M42	73	36	62	17	56	76	6	42	0.75	457	610
PS-M45x4.5-X8	M45	77	38	64	18	57	81	6	44	0.85	700	935
PS-M48x5-X8	M48	83	41	71	19	64	86	6	47	1.10	700	935
PS-M52x5-X8	M52	88	44	74	21	67	94	6	50	1.25	700	935
PS-M56x5.5-X8	M56	97	48	80	22	72	100	6	54	1.60	875	1160
PS-M60x5.5-X8	M60	105	51	84	23	76	110	8	59	2.05	875	1160
PS-M64x6-X8	M64	111	54	88	26	80	120	8	62	2.35	1270	1690
PS-M72x6-X8	M72	125	61	98	29	90	130	8	69	3.15	1270	1690
PS-M76x6-X8	M76	132	64	109	30	-	138	10	74	4.20	1900	2530
PS-M80x6-X8	M80	139	68	120	32	-	145	10	78	5.20	1900	2530
PS-M90x6-X8	M90	156	76	135	36	-	160	10	86	7.10	2530	3380
PS-M100x6-X8	M100	173	85	150	40	-	180	10	95	9.70	2530	3380
PS-M110x6-X8	M110	191	94	165	44	-	202	10	104	13.00	3150	4200
PS-M120x6-X8	M120	208	102	180	48	-	215	12	114	16.75	4200	5600
PS-M125x6-X8	M125	218	108	188	51	-	227	12	120	19.50	4200	5600
PS-M130x6-X8	M130	226	111	195	52	-	234	12	123	21.25	4700	6300
PS-M140x6-X8	M140	243	119	210	56	-	253	12	131	26.25	5250	7000
PS-M150x6-X8	M150	260	127	225	60	-	271	12	139	31.75	5250	7000
PS-M160x6-X8	M160	278	136	240	64	-	290	12	148	38.75	6300	8400

D - gwint | D1 - śr. zewnętrzna | H - wysokość nakrętki | D2 - śr. 6-kąta | SW - szerokość 6-kąta | DS - śr. pierścienia oporowego | S - grubość pierścienia oporowego | L - wysokość całkowita | Fnom - moment nominalny dokręcania | Fmax - moment maks. dokręcania

współpraca z elementami systemów napinających -klasa własności 10

- naprężenia w rdzeniu śruby ~500÷900 N/mm
- temp. pracy -10 ÷ +250°C
- możliwe inne wykonania oraz zarysy gwintów

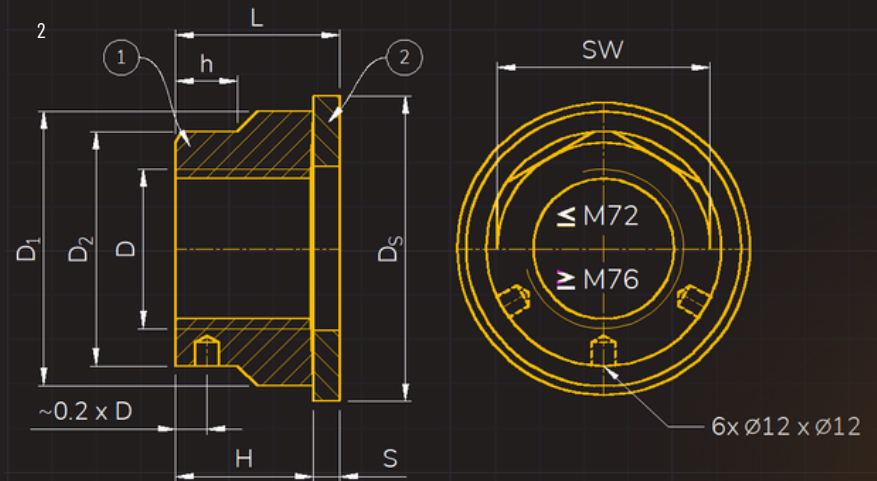

1 - korpus nakrętki
 2 - pierścień oporowy

	D	D1	H	D2	h	SW	DS	S	L	waga	Fnom	Fmax
	[mm]					[mm]				[kg]	[kN]	[kN]
PS-M20x2.5-X12	M20	35	20	30	8	27	38	4	24	0.10	145	185
PS-M24x3-X12	M24	42	24	37	10	33	45	4	28	0.20	215	285
PS-M27x3-X12	M27	47	27	40	11	36	50	5	32	0.25	285	380
PS-M30x3.5-X12	M30	52	30	43	12	39	56	5	35	0.35	285	380
PS-M33x3.5-X12	M33	57	33	47	13	42	63	6	39	0.45	455	610
PS-M36x4-X12	M36	62	36	53	14	48	69	6	42	0.60	455	610
PS-M39x4-X12	M39	66	39	56	15	51	72	6	45	0.70	570	760
PS-M42x4.5-X12	M42	73	42	62	17	56	76	6	48	0.90	685	915
PS-M45x4.5-X12	M45	77	45	64	18	57	81	6	51	1.00	875	1170
PS-M48x5-X12	M48	83	48	71	19	64	86	6	54	1.30	875	1170
PS-M52x5-X12	M52	88	52	74	21	67	94	6	58	1.50	1050	1400
PS-M56x5.5-X12	M56	97	56	80	22	72	100	6	62	1.95	1050	1400
PS-M60x5.5-X12	M60	105	60	84	23	76	106	8	68	2.45	1580	2100
PS-M64x6-X12	M64	111	64	88	26	80	120	8	72	2.85	1580	2100
PS-M72x6-X12	M72	125	72	98	29	90	130	8	80	3.90	1900	2530
PS-M76x6-X12	M76	132	76	109	30	-	138	10	86	5.05	2530	3370
PS-M80x6-X12	M80	139	80	120	32	-	145	10	90	6.15	2530	3370
PS-M90x6-X12	M90	156	90	135	36	-	160	10	100	8.50	3150	4200
PS-M100x6-X12	M100	173	100	150	40	-	180	10	110	12.50	3670	4900
PS-M110x6-X12	M110	191	110	165	44	-	202	10	120	15.50	4200	5600
PS-M120x6-X12	M120	208	120	180	48	-	215	12	132	20.00	4700	6300
PS-M125x6-X12	M125	218	125	188	51	-	227	12	137	22.75	4700	6300
PS-M130x6-X12	M130	226	130	195	52	-	234	12	143	21.25	5250	7000
PS-M140x6-X12	M140	243	139	210	56	-	253	12	151	26.25	5750	7700
PS-M150x6-X12	M150	260	147	225	60	-	271	12	159	31.75	5750	7700
PS-M160x6-X12	M160	278	155	240	64	-	290	12	167	38.75	6300	8400

D - gwint | D1 - śr. zewnętrzna | H - wysokość nakrętki | D2 - śr. 6-kąta | SW - szerokość 6-kąta | DS - śr. pierścienia oporowego | S - grubość pierścienia oporowego | L - wysokość całkowita | Fnom - moment nominalny dokręcania | Fmax - moment maks. dokręcania

osłony elementów złącznych

- dostępne do wszystkich rodzajów nakrętek
- wymiary i konstrukcja dostosowane do wymiarów elementów złącznego

INOX

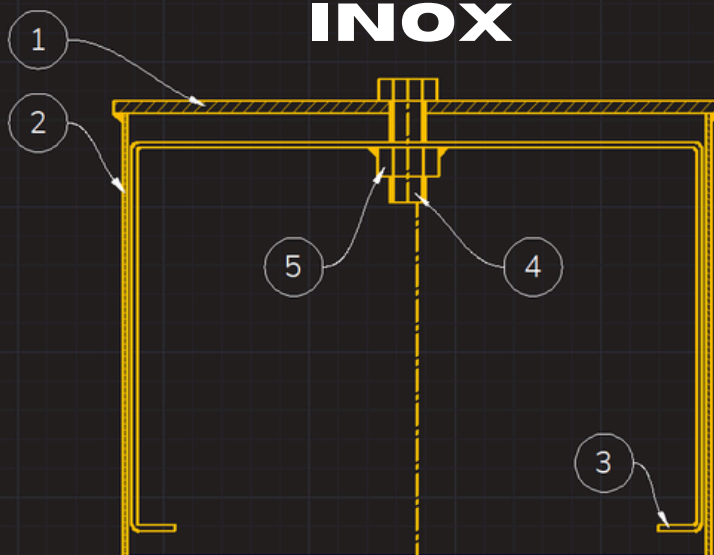

- 1 - dekiel
2 - płaszcz
3 - obejma
4 - śruba
5 - nakrętka

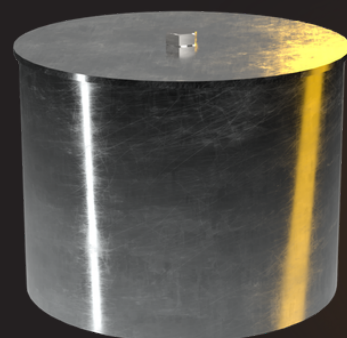

PVC

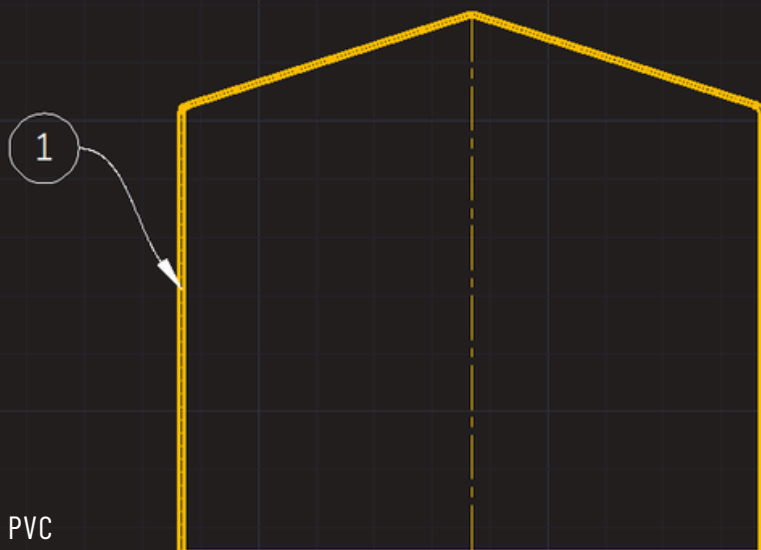

- 1 - osłona PVC

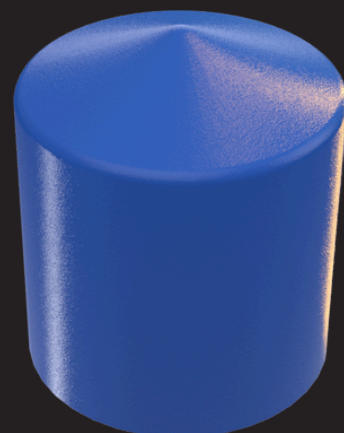

BĄDŹMY W KONTAKCIE

DZIAŁ TECHNICZNO-HANDLOWY

TEL: +48 22 614 38 89

TEL: +48 22 292 53 70

TEL: +48 22 614 12 32

E-MAIL: ZERKOPOL@ZERKOPOL.PL

SEKRETARIAT

TEL: +48 22 811 53 54

E-MAIL: BIURO@ZERKOPOL.PL

UCZNIOWSKA 34
03-112 WARSZAWA